



ANIMA[®]



UNAC
ASSOCIAZIONE COSTRUTTORI DI
INFISSI MOTORIZZATI E AUTOMATISMI
PER SERRAMENTI IN GENERE

Installer:

(Name, address, telephone number)

**UNAC GUIDE No. 11
FOR THE MOTORISATION OF HINGED PEDESTRIAN DOORS
IN ACCORDANCE WITH THE MACHINERY DIRECTIVE 98/37/EEC AND THE STANDARDS prEN 12650-1* - prEN 12650-2***
** The standards mentioned are provisional and refer to the January 2002 version*

With this publication UNAC sets out to inform and assist installers in applying the specifications of the directives and of European standards concerning the safe use of motorised gates/doors.

It should be noted that those who sell and *motorise* an existing manual door/gate become the manufacturer of the motorised door/gate *machine* and must prepare and keep the technical file, as laid down by Annex V of the Machinery Directive (98/37/EEC). The technical file must contain the following documents:

- Assembly drawing of the motorised door/gate (usually included in the installation manual).
- Electrical connections and control circuit diagrams (usually included in the installation manual).
- Risk analysis including (as indicated on the following pages):
 - the list of the essential requirements as indicated in Annex I of the Machinery Directive;
 - the list of the risks presented by the door/gate and the description of the solutions adopted.
- They must also keep the manuals for installation and maintenance of the door/gate and of the components.
- Prepare the operating instructions and general warnings for safety (if necessary integrating those in the manual for installation of the door/gate) and give the user a copy.
- Compile the proof book and give the user a copy (see facsimile in Annex 1).
- Draft the EC declaration of conformity (see facsimile in Annex 3) and give the user a copy.
- Fill in the label or plate with CE marking and attach it to the motorised door/gate.

N.B. *The technical file must be held and made available to the competent national authorities for at least ten years from the date of construction of the motorised door/gate.*

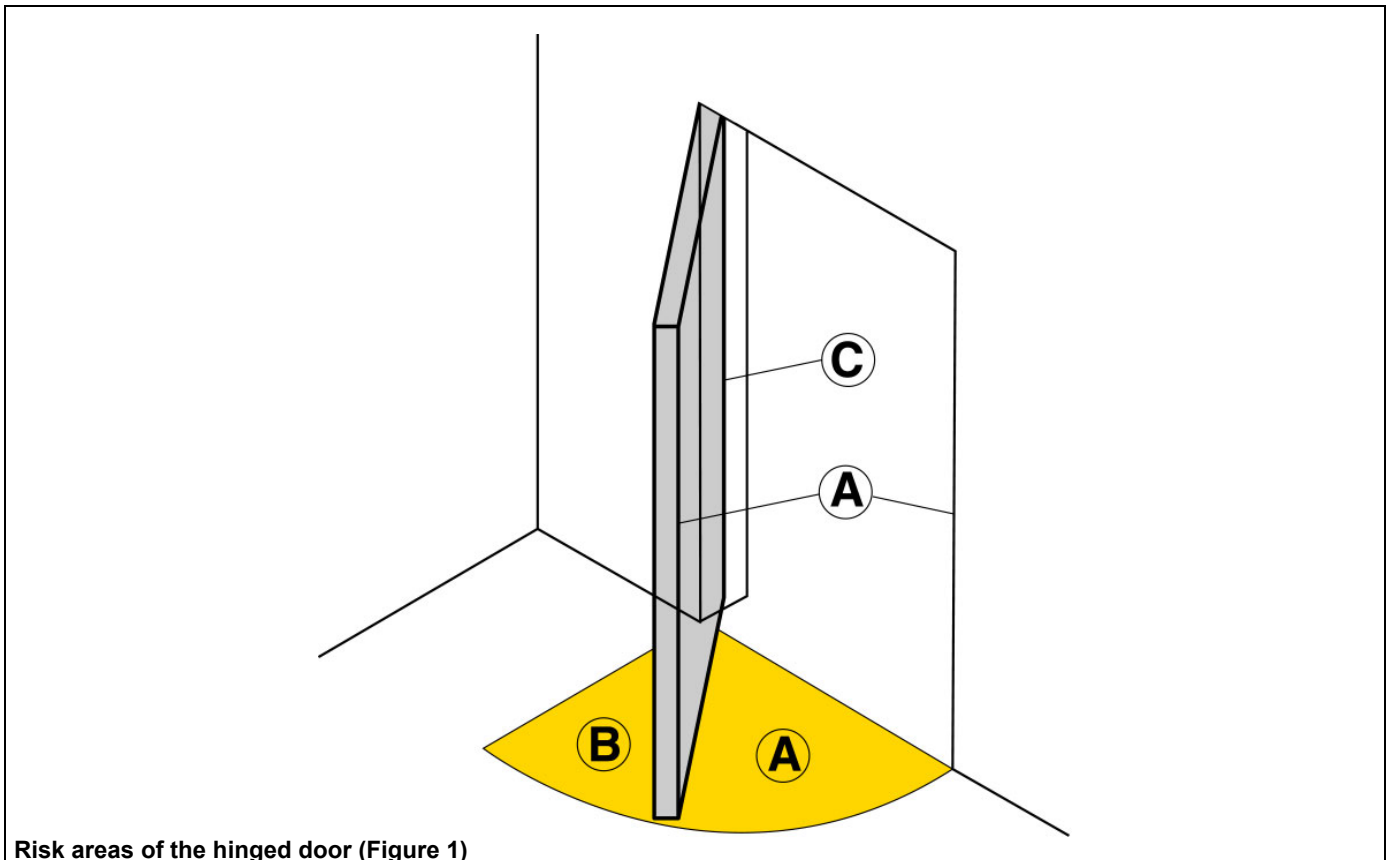

Risk areas of the hinged door (Figure 1)

The information given was drafted and checked with the utmost care, nevertheless UNAC declines all responsibility for any errors, omissions or inaccuracies due to technical or graphical requirements. UNAC points out that this guide does not replace the content of standards which the manufacturer of the motorised door/gate must observe.

KEY TO THE MECHANICAL RISKS CAUSED BY MOVEMENT OF THE DOOR

Pursuant to the Machinery Directive:

- “Danger zones” refer to any zone within and/or around machinery in which an exposed person is subject to a risk to his or her health and safety.
- “Exposed person” refers to any person wholly or partially in a danger zone.

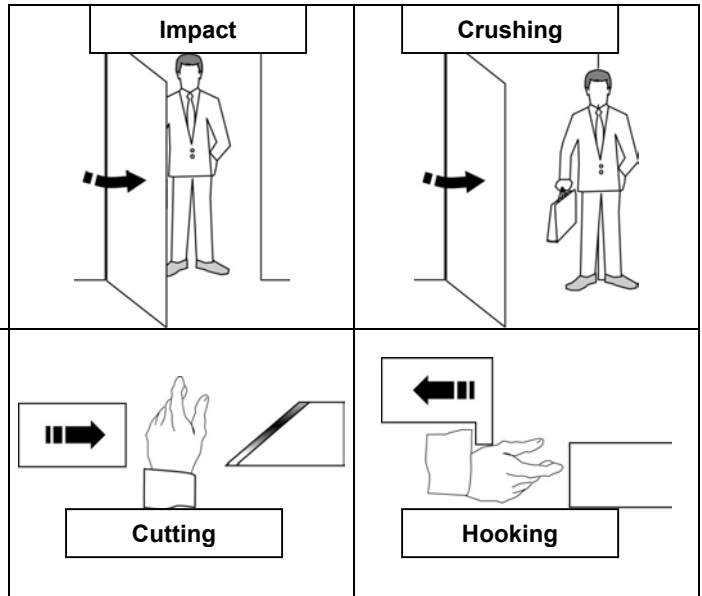

ANALYSIS OF THE RISKS AND CHOICE OF SOLUTIONS

IN ACCORDANCE WITH THE MACHINERY DIRECTIVE 98/37/EEC AND THE STANDARDS EN 13241-1, EN 12453, EN 12445

The risks listed below follow the sequence of the installation process. These risks are those which are commonly present in motorised doors/gates systems. According to the various situations, consideration therefore has to be made of any possible additional risks and exclude those which are not applicable. The solutions to be adopted are those indicated by the standards mentioned above; in the case of risks not dealt with, the safety integration principles indicated by the Machinery Directive (Annex 1 – 1.1.2) have to be applied.

MD Ann. 1	Type of Risks	Evaluation criteria and solutions to be adopted (Tick the box corresponding to the solution adopted)
1.3.1 1.3.2	<i>Mechanical, structural and wear risks</i>	
1.1.2	[1] Preliminary checks.	<input type="checkbox"/> Before starting installation or starting up an automatic door, an inspection has to be carried out on site by professionally skilled staff. This inspection is for evaluating risks and choosing and applying the most appropriate solutions according to the type of pedestrian traffic (intense, limited, one-way, two-way, etc.), the type of users (including the disabled, children, etc.) and the presence of potential dangers or special local situations. The result of this inspection is recorded by compiling this risk analysis.
	[2] Loss of stability and break-up.	<input type="checkbox"/> Check the solidity of the structure installed (architraves, jambs, walls, locks, hinges and leaves) in relation to the weight of the leaves and the forces generated by the drive unit. Attach the drive unit stably, using adequate materials and following the instructions in the installation manual. <input type="checkbox"/> Check that the travel of the leaves is limited (during opening and closing) by mechanical stops of adequate strength. Check that the leaves cannot come out of their pintles or hinges and fall (for example through lifting).
1.5.15	[3] Tripping.	<input type="checkbox"/> Any thresholds in the ground area of the transit space of the door must be appropriately shaped and indicated.
1.1.3 1.3.4	[4] Materials.	<input type="checkbox"/> To build sliding and fixed leaves use materials whose possible breakage does not involve risks of injury. For example, with framed leaves, use laminated safety glass, and for leaves without a frame used hardened glass. Transparent leaves must be appropriately indicated. <i>N.B. Avoid contact between glass and other rigid materials (glass, iron, etc.).</i>

MD Ann. 1	Type of Risks	Evaluation criteria and solutions to be adopted (Tick the box corresponding to the solution adopted)
1.3.7 1.3.8 1.4	Mechanical risks due to movement of the door. Choose one of the following types of installation.	

[5] SOLUTION 1
Impact and crushing on the closing edge
(Figure 1, risk A)

Measure the closure forces (using the instrument required by the standard prEN 12650-1) as illustrated, and check that the values measured by the instrument are below those indicated in the graph.

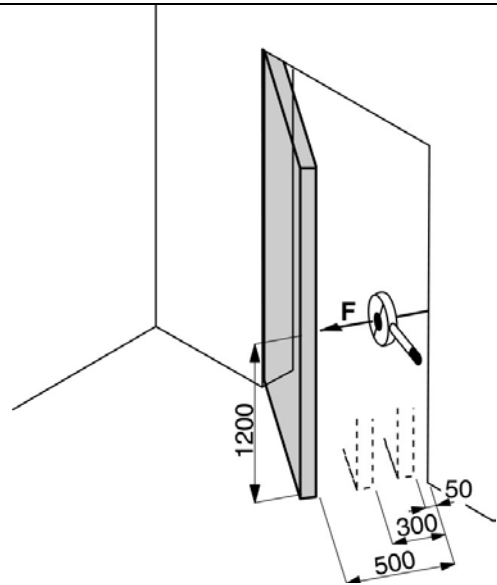
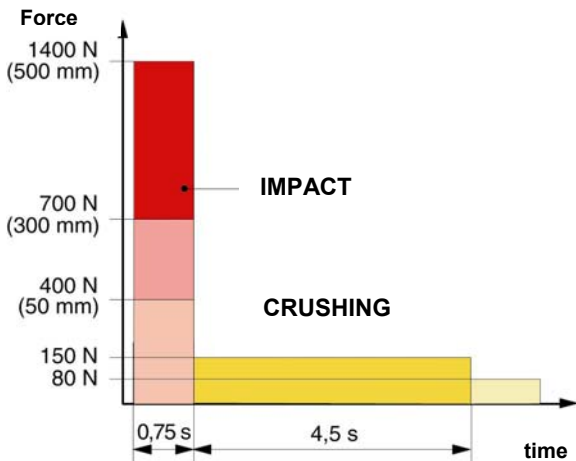

The graph shows the maximum values of the dynamic, static and residual operating forces, in relation to the various positions of the door.

To avoid the risk of the leaves hitting people and causing them to fall (for example the elderly who use a walking stick), the installation of opening sensors is recommended with sensing of presence in the whole transit area, installed if necessary on the mobile leaf. So as to avoid non-monitored side passages, it is possible to border the accesses by means of fixed guards.

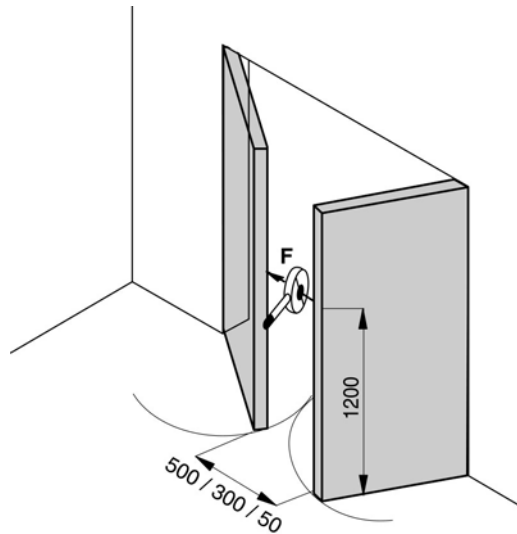

[5] SOLUTION 2
Impact and crushing on the closing edge
(Figure 1, risk A)

Install presence sensing devices (in accordance with the standard EN 12978) that monitor the area of movement of the closing leaves.

N.B. The test specimen for presence sensing is a parallelepiped (700 x 300 x 200 mm) with 3 faces with a light and reflective surface and 3 faces with a dark and opaque surface.

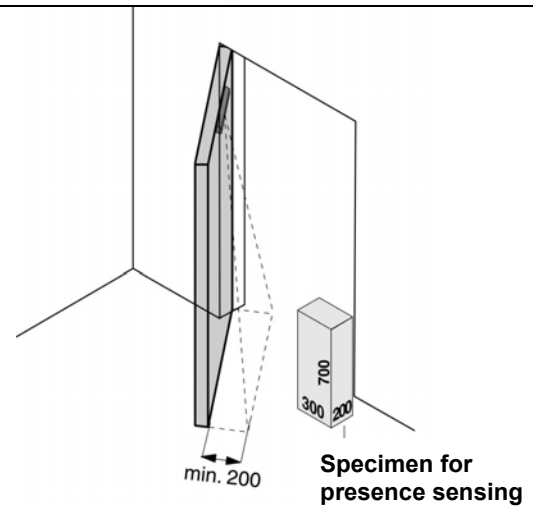

MD Ann. 1	Type of Risks	Evaluation criteria and solutions to be adopted (Tick the box corresponding to the solution adopted)
--------------	---------------	---

[5] SOLUTION 3
Impact and crushing on the closing edge
(Figure 1, risk A)

Install a safety mat (in accordance with the standard EN 12978) in the area of movement of the leaves.

N.B. The mat must be embedded in the floor, or have ramped edges, in order to avoid a step threshold.

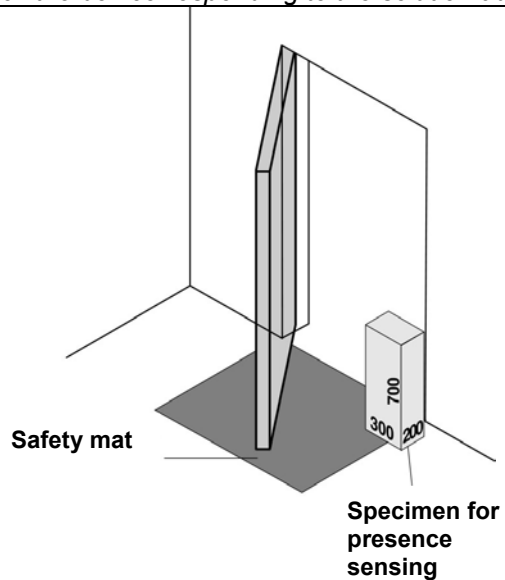

[6] SOLUTION 1
Impact and crushing on the opening edge (Figure 1, risk B)

Check that the safety distances illustrated exist, in the two different cases.



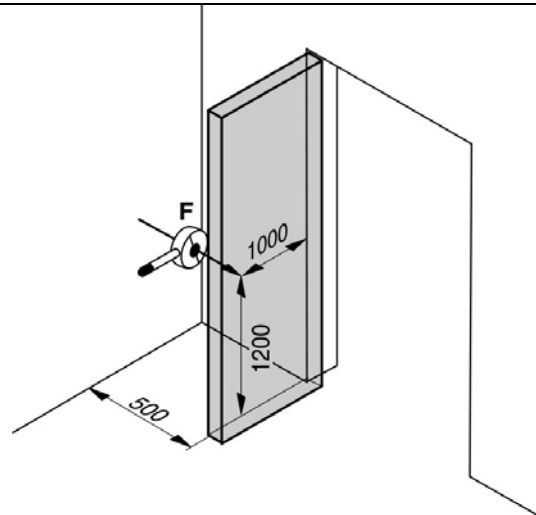
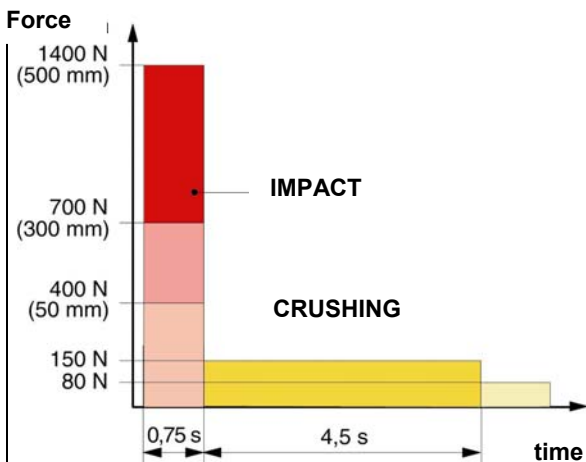

[6] SOLUTION 2
Impact and crushing on the opening edge
(Figure 1, risk B)

Measure the opening forces (using the instrument required by the standard prEN 12650-1) as illustrated, and check that the values measured by the instrument are below those indicated in the graph.

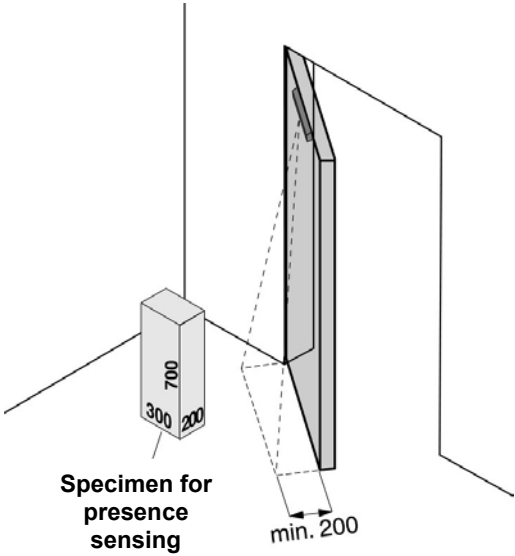
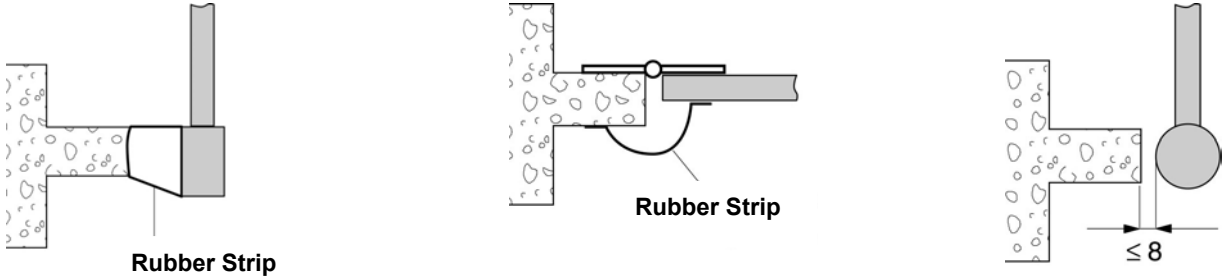

The graph shows the maximum values of the dynamic, static and residual operating forces, in relation to the various positions of the door.

Type of Risks	Evaluation criteria and solutions to be adopted (Tick the box corresponding to the solution adopted)
<p>[6] SOLUTION 3 Impact and crushing on the opening edge (Figure 1, risk B)</p> <p><input type="checkbox"/> Install presence sensing devices (in accordance with the standard EN 12978) which monitor the area of movement of the leaf during opening.</p> <p><i>N.B. The test specimen for presence sensing is a parallelepiped (700 x 300 x 200 mm) with 3 faces with a light and reflective surface and 3 faces with a dark and opaque surface.</i></p>	 <p style="text-align: center;">Specimen for presence sensing</p>
<p>[7] Dragging of hands in the points of rotation of the hinged door (Figure 1, risk C).</p> <p><input type="checkbox"/> Check that the safety distances illustrated exist, in the three difference cases; or</p> <p><input type="checkbox"/> Attach a rubber strip resistant to penetration of fingers.</p>	 <p style="text-align: center;">Rubber Strip</p>
<p>[8] Dragging, hooking and cutting due to shaping of the mobile leaves.</p> <p><input type="checkbox"/> Eliminate or protect any sharp edges, handles, projecting parts, etc. (for example by covers or strips in rubber).</p>	

MD Ann. 1	Type of risks	Evaluation criteria and solutions to be adopted (Tick the box corresponding to the solution adopted)
<p>1.5.1 1.5.2</p> <p>1.5.10 1.5.11</p>	<p><i>Electrical and electromagnetic compatibility risks</i></p> <p>[9] Direct and indirect contacts. Dispersion of electrical energy.</p> <p>[10] Risks relating to electromagnetic compatibility.</p>	 <p><input type="checkbox"/> Use CE-marked components and materials pursuant to the Low Voltage Directive (73/23/EEC).</p> <p><input type="checkbox"/> Carry out the electrical connections, connection to the mains, earth connections and relevant checks, in accordance with current regulations and as indicated in the installation manual of the drive unit.</p> <p><i>N.B. If the electrical supply line is already set up (via both a socket and a connector block), declarations of conformity to Italian law no. 46/90 are not necessary.</i></p> <p><input type="checkbox"/> Use CE-marked components pursuant to the EMC Directive (89/336/EEC). Carry out the installation as indicated in the manual for installation of the drive unit.</p>

MD Ann. 1	Type of risks	Evaluation criteria and solutions to be adopted (Tick the box corresponding to the solution adopted)
	<p><i>Safety and reliability of drive unit and control and safety devices.</i></p>	
1.2	<p>[11] Safety conditions in the event of malfunctioning and power failure.</p>	<p><input type="checkbox"/> Use drive units which comply with the standard prEN 12650-1 and safety devices which comply with the standard EN 12978.</p>
1.5.3	<p>[12] Energy types other than electrical energy</p>	<p><input type="checkbox"/> If hydraulic drive units are used, they must comply with the standard EN 982; or</p> <p><input type="checkbox"/> if pneumatic drive units are used, they must comply with the standard EN 983.</p>
1.2.3 1.2.4	<p>[13] Actuation and disabling of the drive unit.</p>	<p><input type="checkbox"/> Check that, after a fault or power failure, the drive unit restarts safely without creating hazardous situations.</p>
	<p>[14] Power supply switch.</p>	<p><input type="checkbox"/> Install an omnipolar switch for electrical insulation of the door/gate (or use an electrical plug), in accordance with current laws. This switch (or plug) must be positioned or protected against accidental or unauthorised actuation.</p>
1.5.14	<p>[15] Risk of trapping.</p>	<p><input type="checkbox"/> Check that the force necessary for opening or closing the door manually does not exceed 220 N.</p>
1.2.4	<p>[16] Emergency stop.</p>	<p><input type="checkbox"/> If appropriate, install an emergency stop control in accordance with the standard EN 418.</p> <p><i>N.B. Make sure that the emergency stop does not introduce additional risks, aborting operation of the safety devices installed.</i></p>
1.2.5	<p>[17] Opening controls.</p>	<p>If movement sensing devices are used, they should be installed in order to monitor an area of at least 1500 mm from the leaf (completely open, in the case of opening contrary to the direction of transit).</p> <p><i>N.B. Check that the movement sensors see the whole width of the transit space. So as to avoid non-monitored lateral passages, the accesses can be bordered by fixed guards.</i></p> <p><input type="checkbox"/> If mats are used, they should be installed in order to cover the whole width of the transit space (minus 75 mm maximum) and in order to cover a distance of 1000-1500 mm from the leaf (fully open, in the case of opening contrary to the direction of transit). They must also be embedded in the floor, or have ramped edges, in order to avoid a step threshold. Should 2 mats be placed adjacent, the inactive distance must not exceed 60 mm.</p> <p><input type="checkbox"/> The photocells used as opening control are only suitable if used by trained staff. They should be installed 1000-5000 mm from the leaf (fully open, in the case of opening contrary to the direction of transit) and at a height of 300-1000 mm from the floor.</p> <p><input type="checkbox"/> If manual controls are used (for example pushbuttons, magnetic cards, etc.), they must be appropriately positioned and indicated in order to prevent risks or accidental actuation</p>

MD Ann. 1	Type of Risks	Evaluation criteria and solutions to be adopted (Tick the box corresponding to the solution adopted)																																			
1.5.7	<p><i>Environmental risks</i></p> <p>[18] Risk of explosion.</p> <p>[19] Low energy doors used for the transit of the disabled.</p>  <p>[20] Doors used as an escape route and emergency exit.</p>	<p><input type="checkbox"/> If the door is installed in areas with a risk of explosion, it must comply with the requirements of the ATEX directive (94/9/EEC). The electrical parts must comply with the standard EN 50020.</p> <p><input type="checkbox"/> The low energy hinged doors (no higher than 1.6 J) must be able to be regulated so that the minimum times of opening and closure of the leaf (to move through 80°) are in accordance with the table below.</p> <table border="1" data-bbox="579 421 1497 595"> <thead> <tr> <th rowspan="2">Width of the leaf</th> <th colspan="5">Weight of the leaf</th> </tr> <tr> <th>50 kg</th> <th>60 kg</th> <th>70 kg</th> <th>80 kg</th> <th>90 kg</th> </tr> </thead> <tbody> <tr> <td>750 mm</td> <td>3.0 s</td> <td>3.1 s</td> <td>3.2 s</td> <td>3.3 s</td> <td>3.5 s</td> </tr> <tr> <td>850 mm</td> <td>3.1 s</td> <td>3.1 s</td> <td>3.2 s</td> <td>3.4 s</td> <td>3.6 s</td> </tr> <tr> <td>1,000 mm</td> <td>3.2 s</td> <td>3.4 s</td> <td>3.7 s</td> <td>4.0 s</td> <td>4.2 s</td> </tr> <tr> <td>1,200 mm</td> <td>3.8 s</td> <td>4.2 s</td> <td>4.5 s</td> <td>4.8 s</td> <td>5.1 s</td> </tr> </tbody> </table> <p>The minimum time of deceleration of the leaf during closure (last 10°) must be 1.5 s. The time of stopping of the door in an open position must not be less than 5 s. The static force developed by the drive unit must be less than 67 N (measured at 25 mm from the main closing edge). Doors for the disabled must be indicated by appropriate signs.</p> <p><i>N.B. If required by the evaluation of risks, install safety devices so as to prevent contact between the leaf and the person.</i></p> <p><input type="checkbox"/> The leaf of the hinged door must open in the direction of escape by a push not greater than 220 N, attached to the closing edge at a height of 1000 mm.</p> <p><i>N.B. Doors used as escape routes and as fire doors (class A) must be certified by an authorised organisation.</i></p>	Width of the leaf	Weight of the leaf					50 kg	60 kg	70 kg	80 kg	90 kg	750 mm	3.0 s	3.1 s	3.2 s	3.3 s	3.5 s	850 mm	3.1 s	3.1 s	3.2 s	3.4 s	3.6 s	1,000 mm	3.2 s	3.4 s	3.7 s	4.0 s	4.2 s	1,200 mm	3.8 s	4.2 s	4.5 s	4.8 s	5.1 s
Width of the leaf	Weight of the leaf																																				
	50 kg	60 kg	70 kg	80 kg	90 kg																																
750 mm	3.0 s	3.1 s	3.2 s	3.3 s	3.5 s																																
850 mm	3.1 s	3.1 s	3.2 s	3.4 s	3.6 s																																
1,000 mm	3.2 s	3.4 s	3.7 s	4.0 s	4.2 s																																
1,200 mm	3.8 s	4.2 s	4.5 s	4.8 s	5.1 s																																
1.5.6		<p>[21] Fire doors.</p> <p><input type="checkbox"/> The drive unit must close the door automatically after a fire alarm control or in the absence of power supply.</p>																																			
1.7.1 1.7.2	<p><i>Integration principles for safety and information.</i></p> <p>[22] Warnings</p>	<p><input type="checkbox"/> In the case of clear glass leaves, attach clearly visible marking.</p> <p><input type="checkbox"/> Any manual release devices and emergency pushbuttons must be adequately indicated.</p> <p><input type="checkbox"/> Use signs to indicate the use of doors with one-way transit (entrance only/exit only).</p> <p><input type="checkbox"/> Attach all those signs or warnings considered necessary for indicating any unprotected residual risks and to indicate any foreseeable improper use.</p>																																			
1.7.3	<p>[23] Marking.</p>	<p><input type="checkbox"/> Attach the label identifying the product and the manufacturer, with the CE marking.</p>																																			
1.7.4	<p>[24] Instructions.</p>	<p><input type="checkbox"/> Consign to the user the operating instructions, safety warnings and EC declaration of conformity (cf. facsimile in Annex 3).</p>																																			
1.6.1	<p>[25] Maintenance.</p>	<p><input type="checkbox"/> A maintenance plan has to be drawn up and implemented. Check on the proper working of the safety devices at least once a year.</p> <p><input type="checkbox"/> Record the work carried out in the proof book (cf. facsimile in Annex 1).</p>																																			
1.1.2	<p>[26] Unprotected residual risks.</p>	<p><input type="checkbox"/> Inform the user in writing (for example in the operating instructions) of any unprotected residual risks and foreseeable improper use.</p>																																			